

# MERRICK

## SERIES 50 VOLUMETRIC FEEDERS



**Dual-Transverse Chemical Metering  
for Solution Tanks and Dissolvers**

---

---

## 21<sup>ST</sup> Century Technology for a New Concept in Metering

Merrick brings nearly 100 years of chemical feed experience together with new innovations to make a new concept in metering dry chemicals. The Series 50-V Feeder is the world's first volumetric feeder designed specifically for metering difficult materials (such as Aluminum Sulfate) into a solution tank or dissolver.

Traditional screw type feeders are inadequate for feeding today's chemicals for water and wastewater applications. Seal failure is the most common problem facing plant maintenance personnel. Materials such as alum will destroy most seals after a short period of operation. Soda Ash is also very abrasive and difficult to agitate. The Merrick Dual-Transverse patent-pending design eliminates these problems by eliminating the source.

## 21<sup>ST</sup> Century Technology for a New Concept in Control

The heart of the Series 50-V is the Merrick XTRA<sup>®</sup> motor controller. Utilizing a variation of Pulse Width Modulating technology, the drive permits a standard turndown of 60:1 or 100:1 with an optional tachometer. Another benefit is the drive's efficiency. Utilizing a very low form factor, horsepower is not lost as heat. This permits the use of smaller motors to generate an incremental higher horsepower. The elimination of power robbing heat permits the drive to run at maximum turndown 24/7 without concern for motor or drive damage.



NEMA 4X  
Configuration

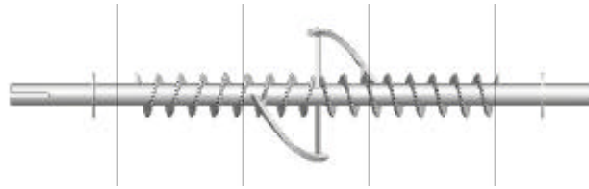

Bi-Directional Auger with  
Conditioning Helix and Bearing Guards

## Reliable Chemical Feed

The Series 50-V is the world's first seal-less design screw feeder. By using a Bi-Directional auger, supported by ball bearings on each end, the chemical is fed in opposite directions and is dispersed into the solution tank at two points of entrance. This eliminates the need for seals and permits slower RPM operation for longer component life.

A unique concentric helix (or overwind) is used to precondition the material and acts as an agitator. The resulting chemical multidirectional movement eliminates the need for supplemental vibrators.

## Easy Maintenance

Dealing with sticky or abrasive chemicals may require access to the feeder internals for cleaning or maintenance. The Series 50-V design maximizes access with easily removed spouts and full size openings on both ends.

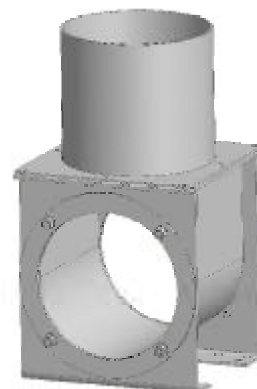

---

## FEATURE BENEFITS

Bi-Directional Auger with Concentric Helix Chemical Conditioner



0.3 to 1 HP DC Motor

0.25 to 0.5 HP High Speed Mixer

Cogged Belt Drive with Taper Lock Hubs



Guard Shield Each End of Auger Prevents Chemical Migration to Ball Bearings

Lift-off Downspout Covers

Feeder Base Serves As Top of Solution Tank

304 Stainless Steel 7 Gauge Construction

Components Easily Removed for Complete Access to Feeder Internals

Lift-off Access Cover

Auger Position Fully Adjustable in Both X & Y Axis for Precision Alignment and Centering

Stainless Steel Ball Bearings with Rear Gaskets to Protect Bearings from Damaging Chemical Dust and Corrosive Solution Fumes

**Feeder Shown on 35 Gallon Solution Tank**

### Options:

- 316 Stainless Steel
- Low Speed Mixers
- Inverter Duty AC Motors and VFD's
- Percentage Timer Control
- Non-Stick Coatings on Auger and Spouts
- Extension Hoppers and Covers
- Hazardous Area Rated Components

### Accessories:

- Solution Tank or Dissolver sizes from 35 to 500 Gallons
  - Day Bins from 24" to 48" in Diameter
  - Silos from 5' to 14' in Diameter
  - Knife Gates
  - Dust Collectors
  - Bin Vents
  - Bag Loading Hoppers
-

## Piping Connections:

- A- (2) 0.75" NPT Water Supplies
- B- 1.5" NPT Overflow
- C- 1.5" NPT (2" for 50 and 75 Gallon Size) Gravity Outlet
- D- 1.5" NPT Drain (or Pump Suction)

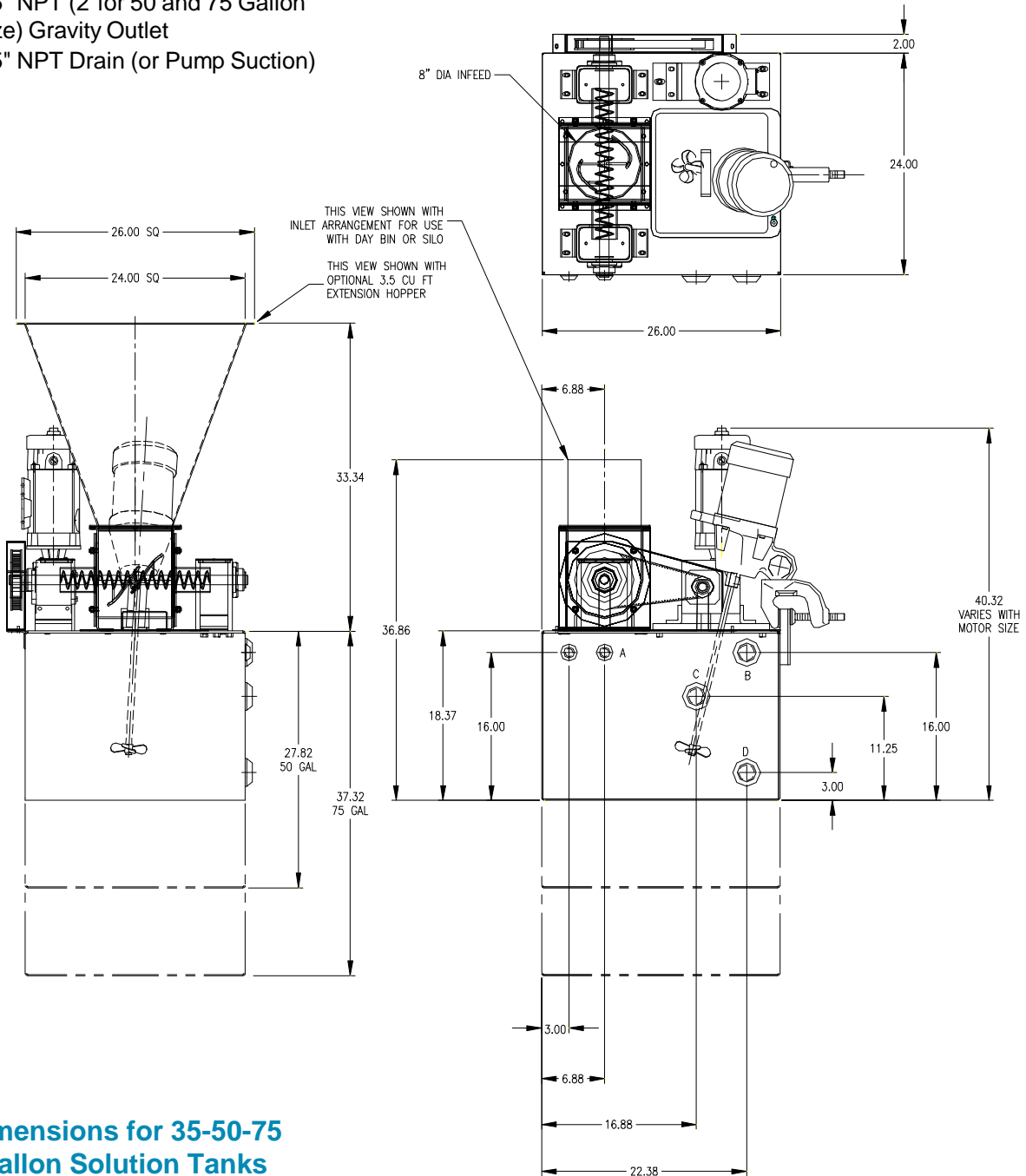

## Dimensions for 35-50-75 Gallon Solution Tanks

**MERRICK**  
MERRICK INDUSTRIES, INC

Merrick Industries, Inc.  
10 Arthur Drive  
Lynn Haven, FL 32444  
Phone: (850) 265-3611  
Fax: (850) 265-1824  
e-mail: info@merrick-inc.com  
www.merrick-inc.com

Merrick de Mexico  
Parral 78, BIS SEXTO PISO  
Deleg. Cuauhtemoc  
Col. Condesa 06140 MEXICO, D.F.  
Phone: (011) (52) (555) 286-3544  
Fax: (011) (52) (555) 553-4063