

FREE-END BRACKET

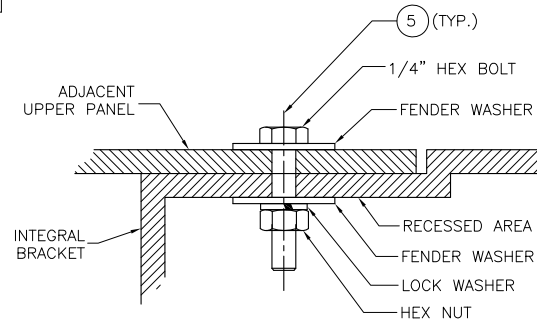

ADJACENT UPPER PANEL CONNECTION

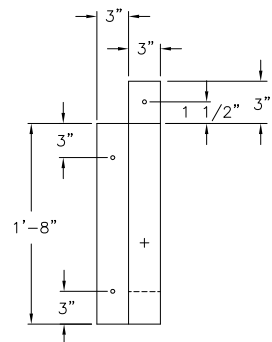
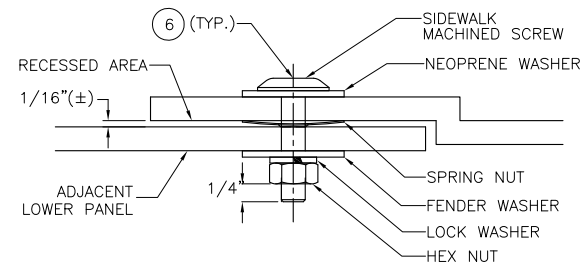

ADJACENT LOWER PANEL CONNECTION

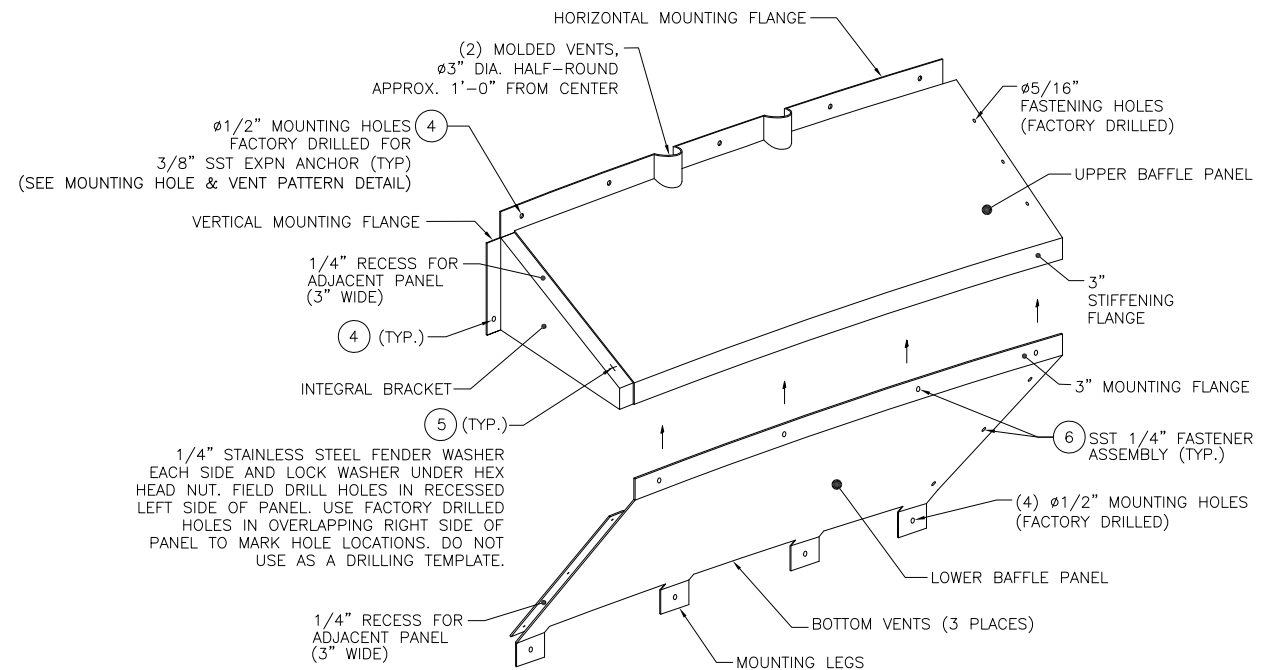

PERSPECTIVE VIEW

NOTES:

- ONE TANK(S), DIAMETER AT BAFFLE = $\phi XX'-X''$.
- BAFFLE PANELS ARE CHOPPED STRAND FRP 1/4" MINIMUM THICKNESS.
- 357-211 PLN CTC GLASS REINFORCEMENT OR EQUIVALENT.
- COREZYN, COR75-AQ-010, ISOPHTHALIC RESIN OR EQUIVALENT, WITH MINIMUM .05% BLACK PIGMENT, MAX 5% FILL AND UV SUPPRESSED. LAMINATE SHALL NOT HAVE LESS THAN 30% GLASS CONTENT. ADD 2' DRAFT TO BRACKET ON PLUG TO COMPENSATE FOR SHRINKAGE.
- ONE-EIGHTH INCH RADIUS ON ALL CORNERS.
- UPPER AND LOWER BAFFLE SURFACES ARE MOLD SMOOTH. UPPER AND LOWER BAFFLE SURFACES ARE LAMINATED WITH ONE LAYER C-TYPE VEIL MAT.
- THE VERTICAL MOUNTING FLANGE AND LOWER PANEL MOUNTING LEGS REINFORCED WITH ONE LAYER 24 OZ WOVEN ROVING.
- PARTS SHALL BE UNIFORMLY BLACK WITH NO FIBER SHOWING.
- PARTS ARE KNIFE TRIMMED, WITH EDGES SANDED AND HOT COATED.
- TANK MOUNTING HOLES ARE FACTORY DRILLED (1/2") AND SEALED.
- SEAL ALL CUT EDGES PER MANUFACTURER'S DIRECTIONS.
- ALL FASTENERS ARE 304 SST UNLESS OTHERWISE NOTED.
- EACH BAFFLE PANEL SHALL HAVE THE FOLLOWING MINIMUM PHYSICAL PROPERTIES:

PROPERTY	TEST	MINIMUM VALUE
TENSILE STRENGTH	ASTM D-638	12,000 PSI
FLEXURAL STRENGTH	ASTM D-790	20,000 PSI
FLEXURAL MODULUS	ASTM D-790	1.0x10 ⁶ PSI
NOTCHED IZOD IMPACT	ASTM D-256	12 FT-LBS/IN
BARCOL HARDNESS	ASTM D-2583	40
WATER ABSORPTION	ASTM D-570	0.2%

© COPYRIGHT 2014 NEFCO, INC.

PATENTS

U.S. PATENT NO.s	5,252,205 & 5,597,483
STAMFORD BAFFLE 2.0	7,971,731
CANADIAN PATENT NO.	2,100,380

MATERIALS / TANK		
ITEM	QTY.	DESCRIPTION
1	##	UPPER BAFFLE PANELS
2	##	LOWER BAFFLE PANELS
3	1	FREE END BRACKET
4	##	3/8" X 3-3/4" EXPANSION ANCHORS, OVERSIZED FLAT WASHERS, HEX NUTS
5	##	1/4-20 X 1-1/2" HEX BOLT, (2) FENDER WASHER, LOCK WASHER, 1/4" HEX NUT
6	##	1/4" SIDEWALK MACHINED SCREW, NEOPRENE WASHER, SPRING NUT, FENDER WASHER, LOCK WASHER, NUT

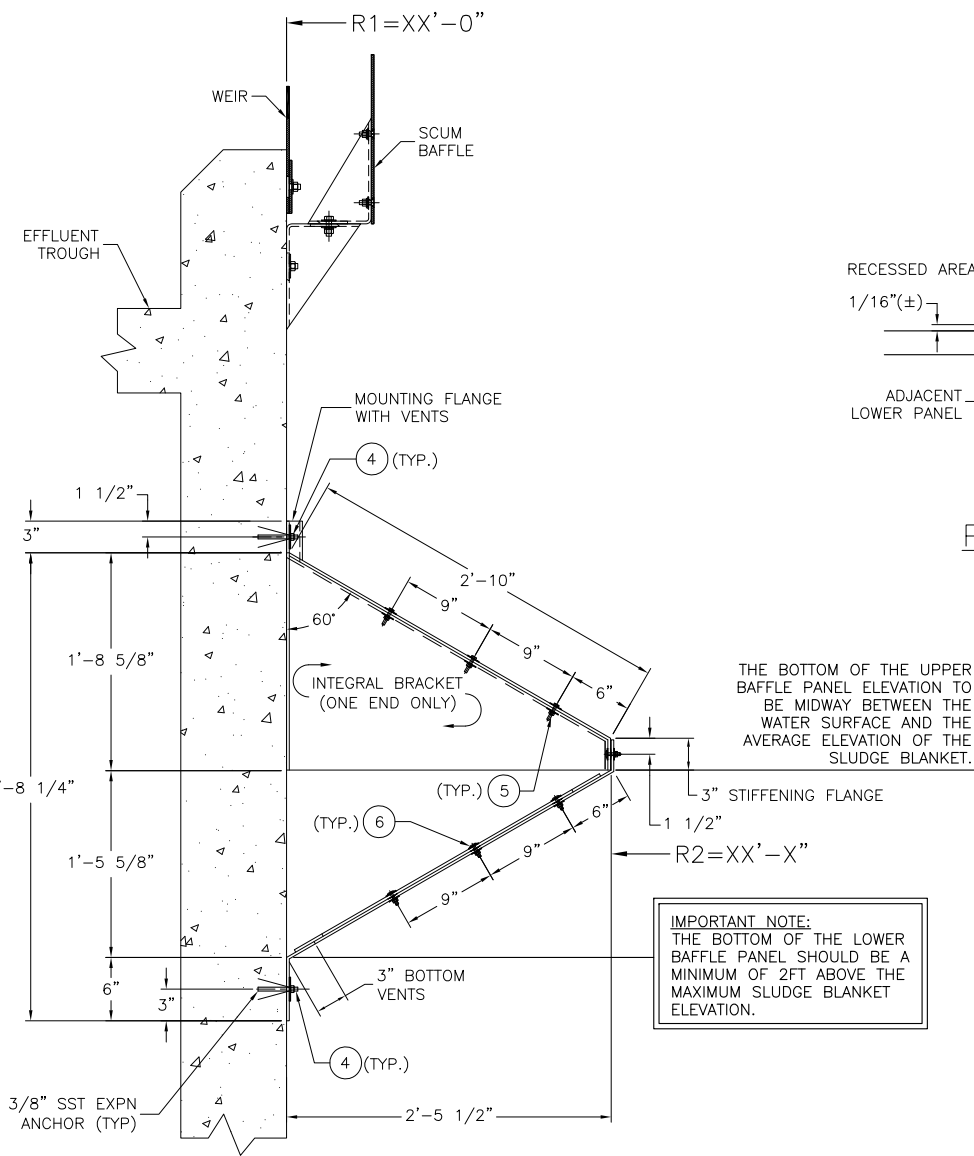

SECTION A-A
END VIEW

IMPORTANT NOTE:
THE BOTTOM OF THE LOWER BAFFLE PANEL SHOULD BE A MINIMUM OF 2FT ABOVE THE MAXIMUM SLUDGE BLANKET ELEVATION.

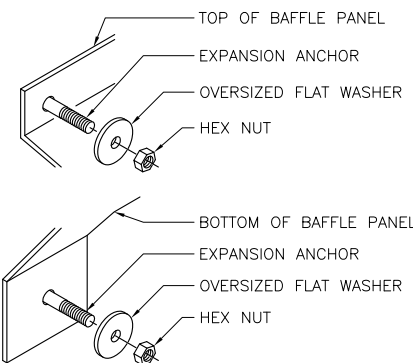

WALL MOUNTING INSTALLATION

REVISIONS:

NO.	DATE	DETAILS

NEFCO, INC.
8895 NORTH MILITARY TRAIL
BUILDING-C, SUITE 100
PALM BEACH GARDENS, FL 33410
(561) 775-9303
www.nefcoinnovations.com



PROJECT:	---
TITLE:	---
CONTRACTOR:	---
ENGINEER:	---

DWG BY: _____
CHK BY: _____
PRJ MG: _____
SCALE: _____ N.T.S.
DATE: 02-11-2014

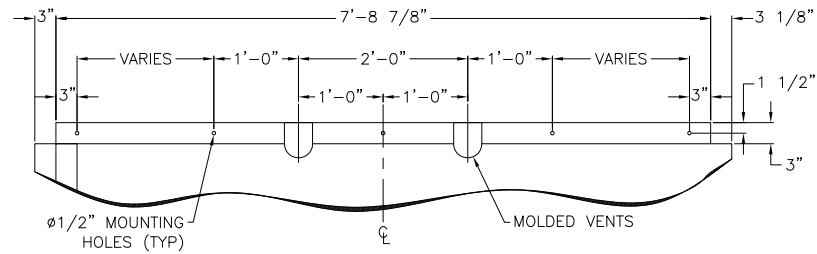

MOUNTING HOLE & VENT PATTERN
(NOT TO SCALE)

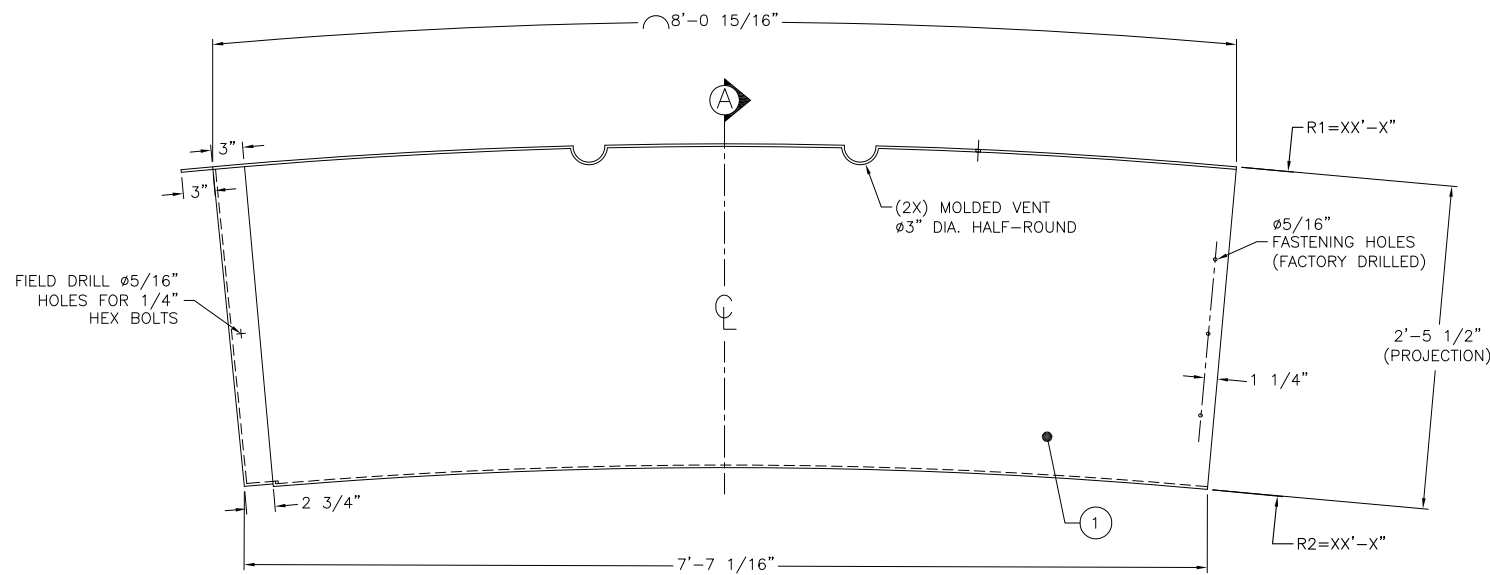

UPPER BAFFLE PANEL

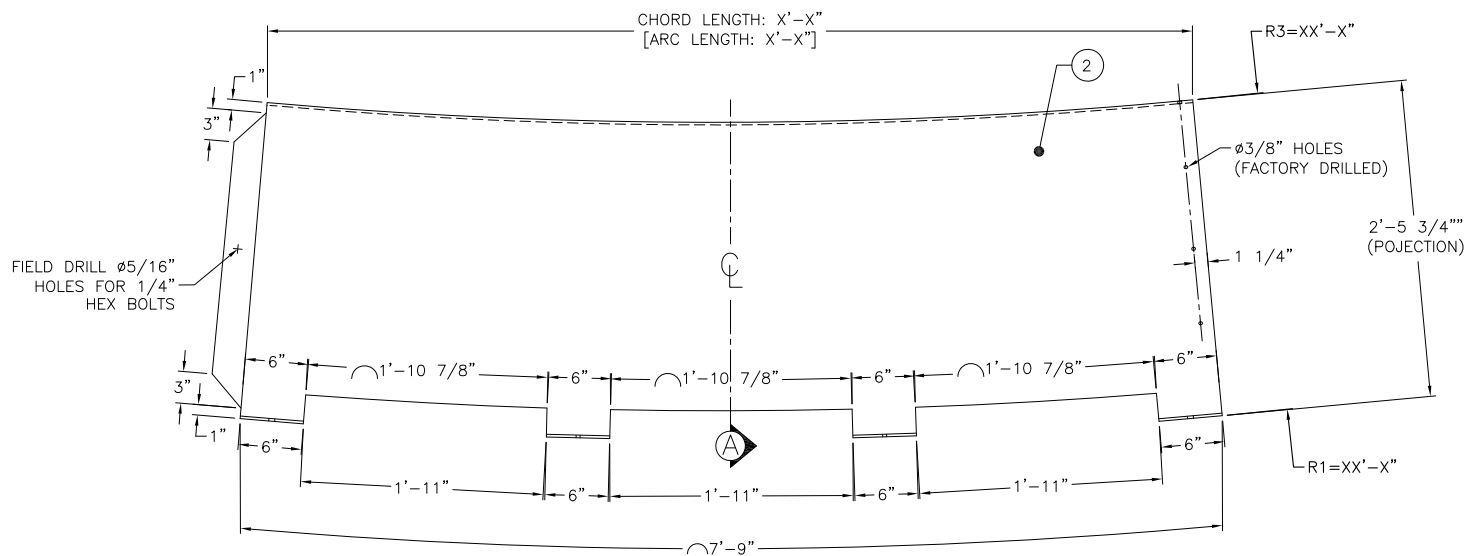

LOWER BAFFLE PANEL

BASIC BAFFLE INSTALLATION INSTRUCTIONS:

NOTE: PLEASE READ THE ENTIRE INSTRUCTIONS BEFORE STARTING THE BAFFLE INSTALLATION!!! IF YOU HAVE ANY QUESTIONS, PLEASE CALL US IMMEDIATELY AT (561) 775-9303. THE BAFFLE PANELS ARE GENERALLY INSTALLED IN A COUNTERCLOCKWISE MANNER TO THE INSIDE SURFACE OF THE TANK WALL ALONG THE CIRCUMFERENCE AS IF LOOKING OUTWARD FROM THE CENTER.

UPPER BAFFLE PANEL INSTALLATION

1) EXAMINE THE PROPOSED LOCATION ALONG THE ENTIRE PERIMETER OF THE TANK AT THE PROPER ELEVATION FOR ANY INTERFERENCE OR OBSTRUCTION.

2) IF NO OBSTRUCTION EXISTS, BEGIN THE INSTALLATION BY MOUNTING THE FIRST UPPER BAFFLE PANEL AT THE PROPER ELEVATION RANDOMLY AT SOME POINT ALONG THE PERIMETER OF THE TANK WALL. USE THE FACTORY MOUNTING HOLES IN THE PANEL AS A GUIDE TO MARK THE WALL PRIOR TO DRILLING THE ANCHOR MOUNTING HOLES. REMOVE THE PANEL AND DRILL THE WALL ANCHOR HOLES (NEVER USE THE FACTORY HOLES AS A DRILLING TEMPLATE). INSERT THE APPROPRIATE ANCHORS INTO THE HOLES, REPLACE THE PANEL AND SECURE IT TO THE WALL WITH THE HARDWARE AS SHOWN IN THE INSTALLATION DETAIL. MOVE TO THE LEFT AND MOUNT THE NEXT PANEL SIMILAR TO THE FIRST. IN ADDITION TO THE MOUNTING HOLES, ALSO MARK THE LAP HOLES ON THE RECESS OF THE INTEGRAL BRACKET OF THE FIRST PANEL MOUNTED USING THE FACTORY HOLES IN THE RIGHT SIDE OF THE SECOND PANEL AS A GUIDE. CONTINUE INSTALLING THE UPPER BAFFLE PANELS FROM RIGHT TO LEFT USING THE SAME STEPS UNTIL YOU REACH THE OPPOSITE SIDE OF THE FIRST PANEL INSTALLED. ACCURATELY MEASURE AND THEN FIELD CUT THE LAST UPPER BAFFLE PANEL TO FIT THE REMAINING SPACE AND INSTALL.

3) IF AN OBSTRUCTION DOES EXIST LIKE THE EFFLUENT BOX OR SCUM PIPE, BEGIN BY MOUNTING THE FREE END BRACKET AT THE DESIRED ELEVATION TO THE LEFT SIDE OF THE OBSTRUCTION. INSTALL THE FIRST BAFFLE PANEL TO THE LEFT SIDE OF THE FREE END BRACKET USING THE SAME METHOD AS IN STEP-1 ABOVE. LAP THE RIGHT SIDE OF THE PANEL ON TOP OF THE FREE END BRACKET. MARK THE LAP HOLES ON THE FREE END BRACKET USING THE FACTORY HOLES IN THE RIGHT SIDE OF THE PANEL AS A GUIDE. AGAIN, REMOVE THE PANEL BEFORE DRILLING. CONTINUE INSTALLING UPPER BAFFLE PANELS FROM RIGHT TO LEFT UNTIL YOU REACH THE OPPOSITE SIDE OF THE OBSTRUCTION. ACCURATELY MEASURE AND THEN FIELD CUT THE LAST BAFFLE PANEL TO FIT THE REMAINING SPACE AND INSTALL.

LOWER BAFFLE PANEL INSTALLATION

1) START INSTALLATION AT THE FIRST UPPER BAFFLE PANEL INSTALLED.

2) USE THE FACTORY DRILLED MOUNTING HOLES IN THE LOWER BAFFLE PANEL AS A GUIDE TO MARK THE WALL AND UPPER BAFFLE PANEL PRIOR TO DRILLING THE MOUNTING AND ANCHOR HOLES. REMOVE THE PANEL AND DRILL THE MOUNTING AND WALL ANCHOR HOLES (NEVER USE THE FACTORY DRILLED HOLES AS A DRILLING TEMPLATE). INSERT THE ANCHORS INTO THE WALL AND THE SIDEWALK MACHINE SCREWS WITH NEOPRENE WASHER INTO THE UPPER PANEL MOUNTING HOLES. INSTALL THE SPEED NUTS ONTO THE SIDEWALK MACHINE SCREWS. REPLACE THE PANEL AND SECURE IT TO THE WALL AND UPPER BAFFLE PANEL WITH THE HARDWARE AS SHOWN IN THE INSTALLATION DETAIL. MOVE TO THE LEFT AND MOUNT THE NEXT PANEL SIMILAR TO THE FIRST. IN ADDITION TO THE MOUNTING HOLES, ALSO MARK THE LAP HOLES ON THE RECESS OF THE FIRST LOWER BAFFLE PANEL MOUNTED USING THE FACTORY HOLES IN THE RIGHT SIDE OF THE LOWER BAFFLE PANEL BEING INSTALLED AS A GUIDE. CONTINUE INSTALLING PANELS FROM RIGHT TO LEFT USING THE SAME STEPS UNTIL YOU REACH THE OPPOSITE SIDE OF THE FIRST PANEL INSTALLED. ACCURATELY MEASURE AND THEN FIELD CUT THE LAST LOWER BAFFLE PANEL TO FIT THE REMAINING SPACE AND INSTALL.

REVISIONS:	NO.	DATE	DETAILS

NEFCO, INC.
8895 NORTH MILITARY TRAIL
BUILDING-C, SUITE 100
PALM BEACH GARDENS, FL 33410
(561) 775-9303
www.nefcoinnovations.com



PROJECT:	---
TITLE:	---
CONTRACTOR:	---
ENGINEER:	---
P.O.:	---

DWG BY:
CHK BY:
PRJ MG:
SCALE: N.T.S.
DATE: 02-11-2014

DWG NO.
SHEET NO: 2 OF 2